

**ADVANTEST**<sup>®</sup>

Spectrum Analyzers

# U3771/3772

Handling frequencies of up to 43 GHz!! Our new microwave spectrum analyzer, ideal for field use, is now available.



# A New Standard for Microwave and Millimeter-wave Spectrum Analyzers

The world's smallest and lightest microwave spectrum analyzer handles frequencies of up to 43 GHz.

As the pace of radio communications development worldwide continues to increase daily, operating frequency bands have widened from microwave bands to include millimeter-wave bands. The U3771/3772 sets a new standard for microwave spectrum analyzers. An analyzer that combines portability, a quality required for inspecting and servicing different types of communication systems, with maximum functionality in the field. Making full use of the newest digital circuit and software technology in the world's smallest and lightest (less than 6 kg) form factor, the U3771/3772 achieves dramatic advances in level measurement accuracy and stability. Employing leading edge software technologies to provide image suppression capabilities and an array of data analysis functions as standard features. This field-use spectrum analyzer employs 3-way power operation (battery, DC and AC), warms up quickly (within 5 minutes) and has a USB interface enabling the use of large-capacity memory for data storage.

\*: As of July 2007

## U3771/3772 Web Demonstration

Please access to the <http://www.advantest.co.jp/en-index.shtml> and click on the following links.

**PRODUCTS & SUPPORT** ▶ **Electronic Measuring Instruments** ▶ **Products** ▶ **U3771/U3772**

31.8 GHz

43 GHz

for File

## Compact Size

- Size and weight half that of existing spectrum analyzers with similar features
- Optimized for use in field maintenance tasks and surveys



## 5 min. Warm-up

- All but eliminates preheat time considerations
- Reaches operational specifications (level measurement accuracy) within just 5 minutes

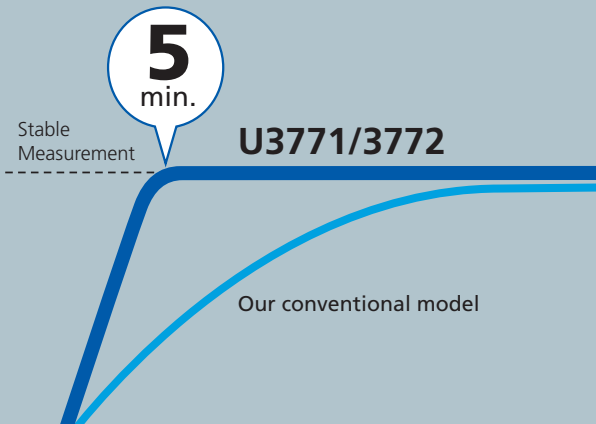

## USB Interface

- Support for USB for printer and memory
- Storage Image formats:  
PNG, BMP
- Configuration file:  
BIN, XML



## Operating with battery

- Includes a detachable battery pack
- Can operate continuously for up to 2 hours after a full-charge time of 5.5 hours



id

### High-input Sensitivity

As measured frequencies become higher, noise level degradation places limits on measurement dynamic range. The latest RF technologies are incorporated in the U3771/3772 to reduce the noise floor level.  
 -117 dBm@34 GHz (typ.)

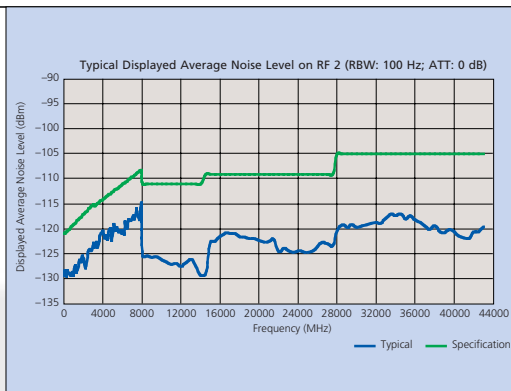

Displayed average noise level (typical)

### Broadband Sweep

The U3771/3772 continuously sweeps across a frequency band of 10 MHz to 31.8 or 43 GHz allowing high-speed sampling of data on a single screen, simplifying broadband signal monitoring and harmonics measurement tasks.

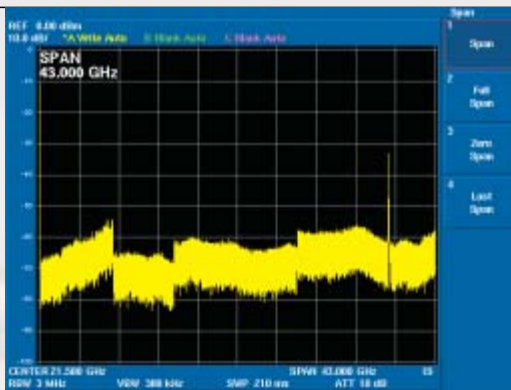

Full-span measurement

### Two-Channel Display

The U3771/72 has two RF inputs: RF input 1 (9 KHz to 8 GHz) and RF input 2 (10 MHz to 31.8/43 GHz). By feeding different signals to the respective input ports, a spectrum display can be produced on the UPPER/LOWER screen. All of the settings for the UPPER/LOWER screen are independent of one another, allowing the product to function as a simple, two-channel spectrum analyzer.

\* The two-channel display function uses single-sweep operation.

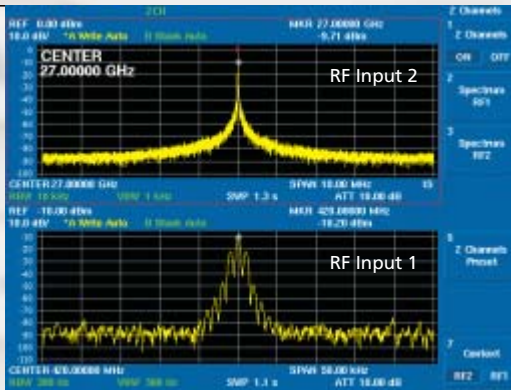

Measurement using a two-channel display

### RMS Detector

The U3771/3772 include an RMS detector in addition to the traditional sample detector to increase its accuracy in broadband modulated signal power measurements. The RMS detector, the digital IF, and the software calibration function work together to provide higher-stability power measurement.

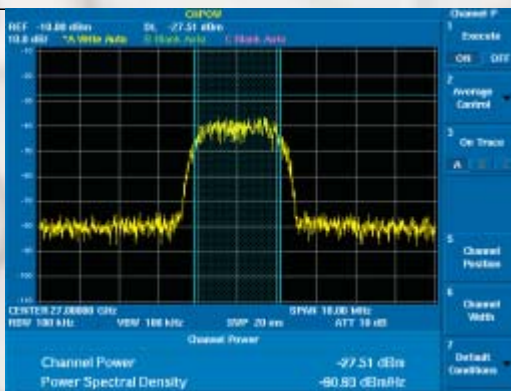

Channel power measurement

### Image Suppression Function Useful for removing Images

Software pre-selector technology has been incorporated into the U3771/3772 to make a compact, lightweight, and inexpensive spectrum analyzer. The Image Suppression (IS) function allows you to identify and delete images easily. The U3771/3772 comes with the IS function enabled by default for operation as easy as that of a conventional model.

*Note: The IS function is intended to determine whether the signal under test is a true or image signal. Set the IS function to OFF for detailed signal or modulated signal analysis, or for high-speed measurement.*

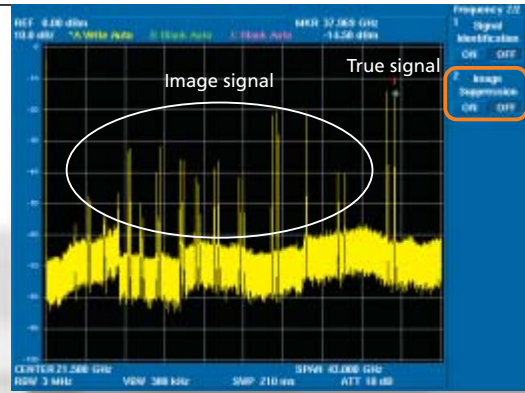

Image Suppression OFF

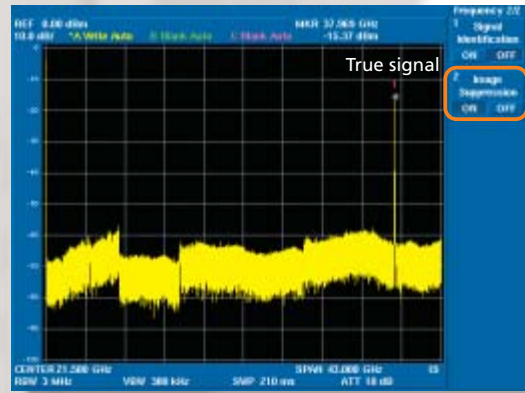

Image Suppression ON

### Zoom Function

An example of a pulsed RF signal measured with the Frequency-Time (F-T) mode analysis feature of the zoom function is shown below. The U3771/3772 displays the pulse envelope (frequency domain) of double pulses (5- $\mu$ s delay) having a pulse width of 1  $\mu$ s and a pulse waveform (time domain) on separate screens. Additional features provided by the U3771/3772 support a wide variety of analysis tasks including Frequency-Zoom mode, in which different frequency spectra are displayed, and T-T display mode, which is useful for displaying expanded views of the time domain.



F-T mode analysis

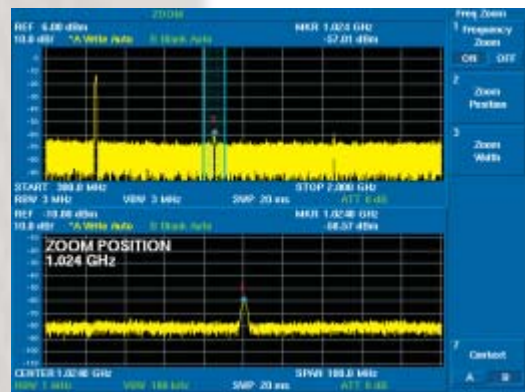

Freq. Zoom mode analysis

### Millimeter wave frequency measurement

By pointing the marker at the signal to be measured, the U3771/72 can be used as a frequency counter of up to 31.8/43 GHz. Measurement resolutions of from 1 Hz to 1 kHz can be selected.

Using the marker counter function, which makes use of span accuracy, makes possible high-speed signal frequency confirmation when checking millimeter-wave modulation frequencies. (Resolution is determined by span setting.)

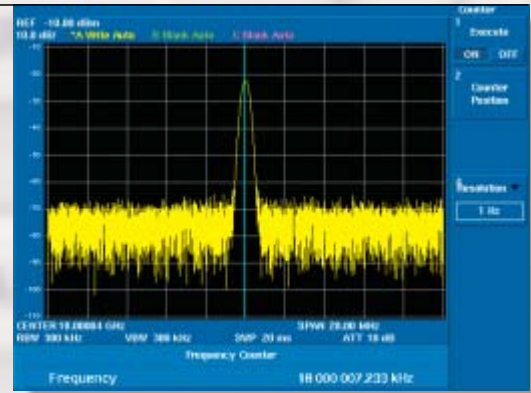

Frequency counter measurement

### OBW Measurement Function

The U3771/3772 computes the bandwidth of a specified power ratio from measured spectrum data and displays the occupied bandwidth (OBW) and the center frequency (Fc). The OBW of 10 to 99.8% of total power can be chosen.

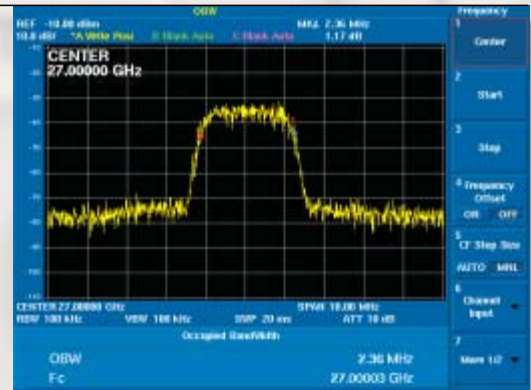

OBW measurement

### Harmonics Measurement Function

The harmonics measurement function is optimal for measuring spurious response for wireless applications. To measure harmonic spurious response, simply entering or place a marker on the fundamental frequency. Up to 10 orders of harmonics can be measured and displayed.

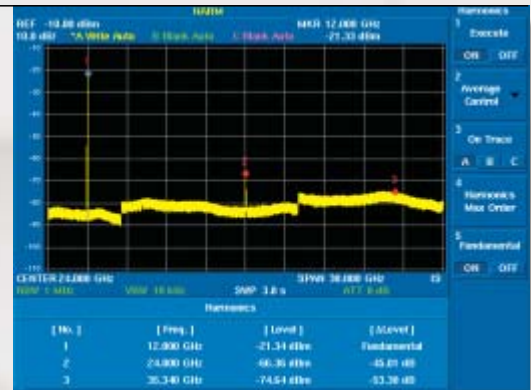

Harmonic spurious response measurement

#### Other Measurement Functions

- Channel power
- Total power
- Average power
- Spurious measurement
- Frequency counter
- Adjacent channel leakage power measurement
- Spectrum emission mask
- Noise-Hz conversion
- XdB down
- Intermodulation
- Dual-screen display

#### Diverse Detector Types

- Normal
- Positive peak
- Negative peak
- Sample
- RMS

#### Marker Function

- Multimarker (10 markers)
- Delta marker
- Peak search

**Optimal for Monitoring, Remote Control via a LAN**

A 10/100BASE-T LAN port is provided as standard equipment, enabling remote control from a personal computer. The U3771/3772 can be installed at a remote-controlled station, such as an unattended, wireless transmission station, and signal output can be measured and observed through remote control and monitoring from a distant location.

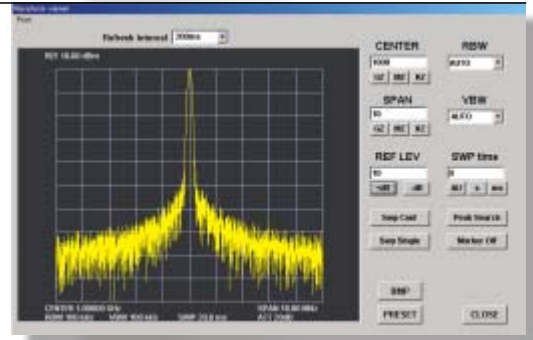
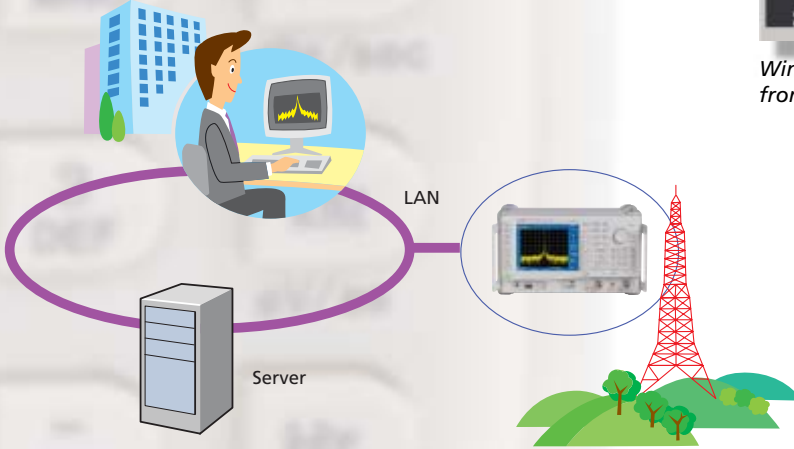

Window for remote control and monitoring from a personal computer via a LAN

**Searching for the location of a fault in a coaxial cable**

When used with its tracking generator option and the sample software for an external PC, the U3771/3772 can measure the distance to the failure point (open/short) in a coaxial cable. This application permits this distance to be measured from one end of the coaxial cable.

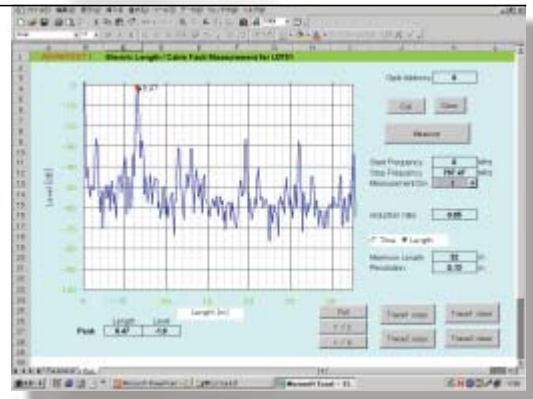
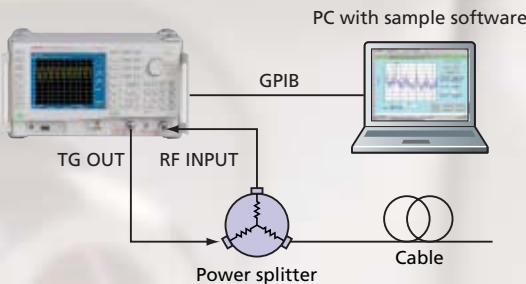

Cable fault point distance measurement

**Evaluation of microwave oscillation circuits and microwave module characteristics**

Using sample software on an external PC, the U3771/72 is an effective tool for evaluating phase noise characteristics of microwave oscillation circuits and microwave modules. Offset frequency from a carrier can be optionally set, making it easy to create a graph. Additionally, RMS jitter can be obtained from the power spectrum, simply by setting the frequency band.

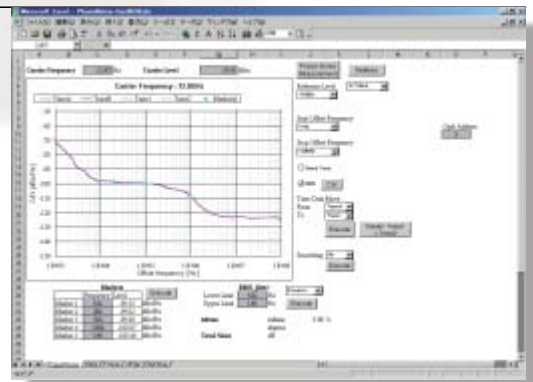

Phase noise measurement using sample software

**Option Guide**

		Main unit support	
		1 ch	2 ch
<b>2 Channel input (50 Ω)</b>	<b>OPT.10</b>	—	1)
<b>High-Stability Frequency Reference Source</b>	<b>OPT.20</b>	●	●
<b>EMC Filter</b>	<b>OPT.28</b>	●	●
<b>Time-Domain Analysis (1 ch/2 ch)</b>	<b>OPT.53/54</b>	●	●
<b>Wide-Band Time-Domain Analysis (1 ch/2 ch)</b>	<b>OPT.55/56</b>	●	●
<b>High-Purity Spectrum Analysis (1 ch/2 ch)</b>	<b>OPT.70/71</b>	●	●
<b>Tracking Generator (3 GHz)</b>	<b>OPT.76</b>	●	—
<b>Tracking Generator (6 GHz)</b>	<b>OPT.77</b>	●	—

1): When OPT.10 is installed, the standard equipment, 9 kHz to 8 GHz, is deleted, RF1 is 10 MHz to 31.8 GHz (U3771)/10 MHz to 43 GHz (U3772), and RF2 is 9 kHz to 3 GHz.  
 2): One must be selected from OPT.76/77.

**High-Stability Frequency Reference Source OPT.20**

Frequency of the high frequency signal was conventionally counted with a frequency counter. However, multi-carrier method is often employed for the recent communication system which uses high frequency signals which contains multiple frequency components, a frequency counter cannot count the frequency correctly. Therefore, the frequency counter of the spectrum analyzer attracts attention as an essential function. In a spectrum analyzer, just by pointing the marker at the spectrum separated as a sine wave of CW, not only the frequency counting but also faint signal level counting is possible. OPT.20 improves the aging stability of the standard oscillator which determines the frequency counter accuracy of a spectrum analyzer.

	Aging rate
Standard	$\pm 2 \times 10^{-6}/\text{year}$
OPT.20	$\pm 2 \times 10^{-8}/\text{day}, \pm 1 \times 10^{-7}/\text{year}$

**EMC Filter OPT.28**

Option 28 adds 6 dB RBW CISPR bandwidths for EMI measurement of 200 Hz, 9 kHz, 120 kHz, and 1 MHz. A broadband sweep by the spectrum analyzer is very effective at measuring noise emitted from electrical devices. Installing OPT.28 allows measurement in CISPR-specified bandwidths. It enables simple, fast measurement using the Positive peak detector and Max Hold, which makes it effective at compensating for emitted noise. It guarantees an impulse bandwidth accuracy of 1 MHz. This capability conforms to the standard for noise measurement of 1 GHz or above.

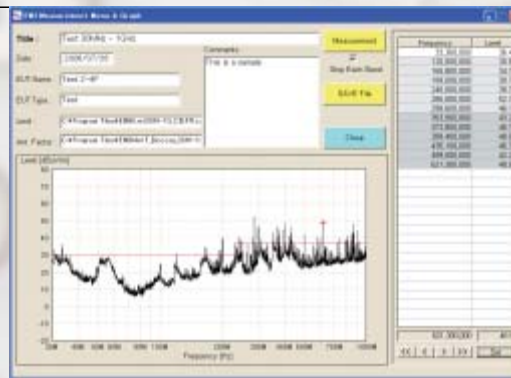

Measurement using EMI sample software

## 2 Channel Input OPT.10

Two-channel input option (OPT.10) offers two independent lines of RF input. Various measurement conditions including measuring frequency and spans can be set independently for each RF input.

### High-speed process by the parallel processing

- Simultaneous measurement of standard items (Channel power and OBW, etc.)
- Reduction in time by two-piece simultaneous measurement
- Simultaneous measurement of the different system, etc.
- Simultaneous measurement of different frequency (1 GHz or less and micro-wave) etc. at EMC measurement

### Applications only possible for a two-channel spectrum analyzer

- Timing measurement between two channels by the synchronized sweep and synchronized trigger
- Simultaneous spectrum observation of the different frequency by the synchronized sweep when sweeping time is the same
- Simultaneous observation of the whole/part by the synchronized trigger
- Simultaneous monitoring of input/output devices

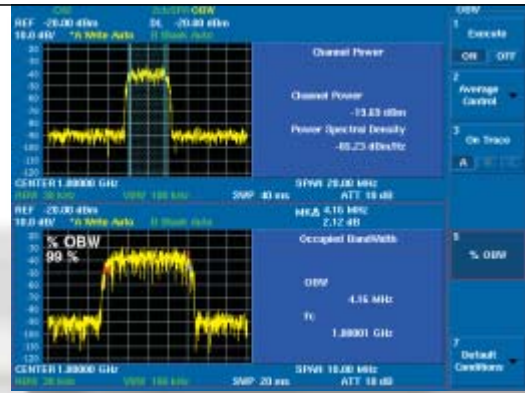

Simultaneous measurement of Cannel Power and OBW

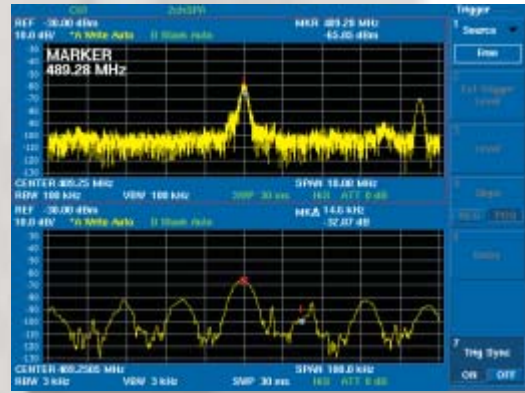

Simultaneous measurement of the broadband/narrowband by the synchronized sweep

### Allocating Connectors on Front Panel (for U3772)

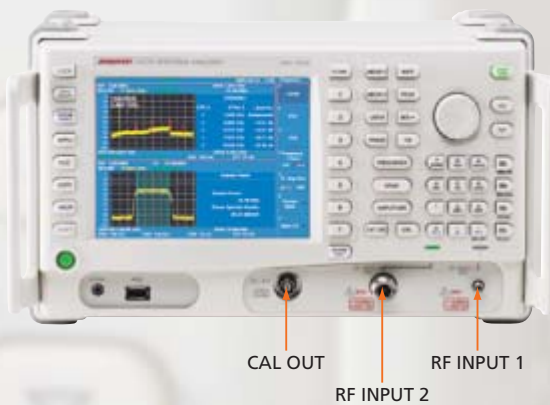

Simultaneous measurement of input/output for feed-forward amp

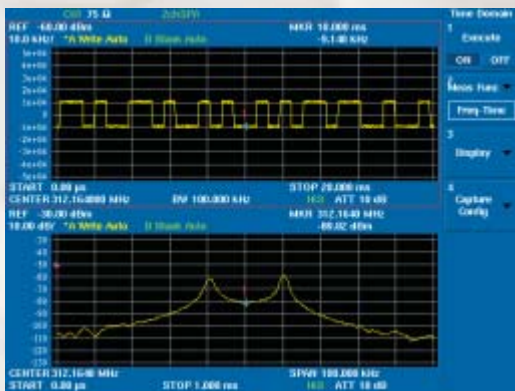

FSK signal measurement (required with OPT.54)

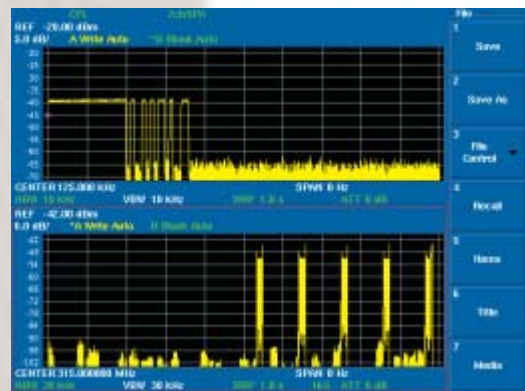

Timing measurement of TPMS by the synchronized trigger

**Time-Domain Analysis OPT.53 (1 ch)/54 (2 ch)**  
**Wide-Band Time-Domain Analysis OPT.55 (1 ch)/56 (2 ch)**

By installing this option in addition to the function of the conventional sweeping-type spectrum analyzer, a the time-domain analysis basic functions is added at low-cost.

**Signal observation based on a domain different from sweeping-type spectrum analyzer**

- Change in frequency over time by *Freq. vs. Time analysis* (ex. analysis of FSK signals, such as keyless entry and TPMS)
- Change in phase over time by *Phase vs. Time analysis*
- Change in power over time by *Power vs. Time analysis*
- High resolution (equivalent of 1 Hz RBW) high sensitivity measurement by FFT

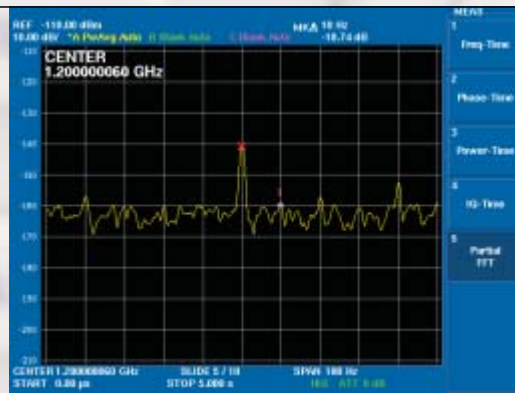

High sensitivity measurement by FFT (RBW 1Hz, -160 dBm/Hz (typ))

**Time-domain analysis for two signals (OPT.54/56)**

The time-domain basic analysis function in the range of 9 kHz to 43 GHz (on main body) can be installed simultaneously for 2 channels. Unique analysis functions, such as Freq. vs Time during input and output are realized.

**Wide-band time-domain analysis (OPT.55/56)**

In the frequency ranges of 9 kHz to 43 GHz (on main body), time-domain analysis for up to the maximum measurement bandwidth 40 MHz is possible.



FREQ. vs. Time measurement of the 4 value FSK

Measurement using the time-domain basic analysis function

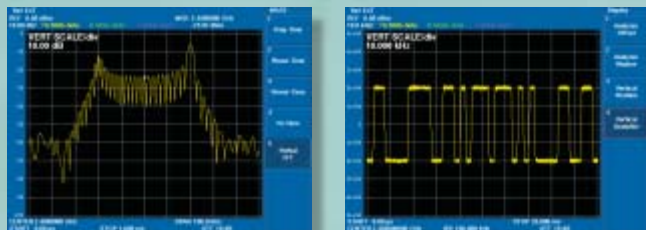

FFT Spectrum

Freq. vs. Time

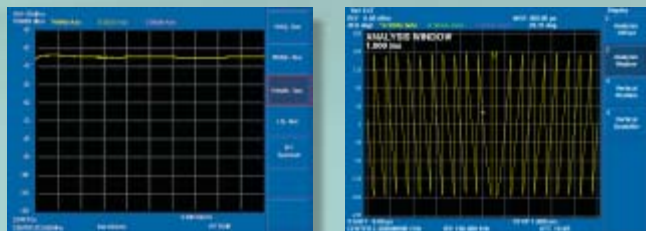

Power vs. Time

Phase vs. Time

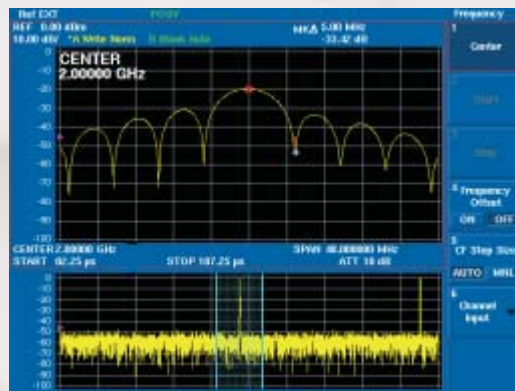

Radar wave measurement (OPT.55 for Wide-band time-domain analysis)

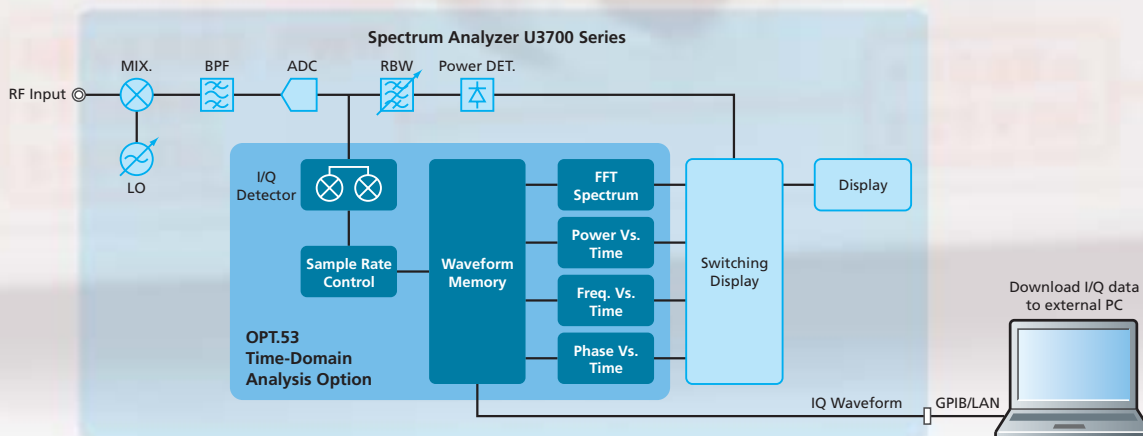

### High-Purity Spectrum Analysis OPT.70 (1 ch)/71 (2 ch)

Phase noise measurement is indispensable to evaluation of the characteristics of high-frequency oscillation circuits or modules. The high-purity spectrum analysis option offered with the U3700 series can improve the phase noise measurement performance of the spectrum analyzer. Because the performance can be selected, selecting the most suitable spectrum analyzer for the device under test (DUT) is simple. At the same time, the added resolution bandwidth of 30 Hz enables reduction of the display average noise level and analysis in a high dynamic range.

2 channel-inputs option (OPT.10) is required for OPT.71 installation.

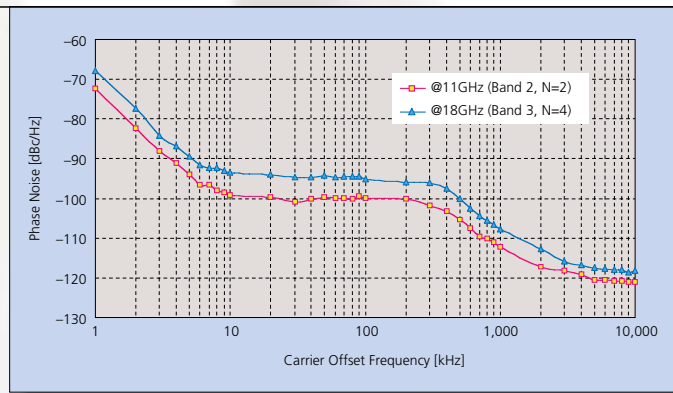

Phase noise characteristic graph (representative values)

### Tracking Generator OPT.76/77

Generates synchronized signals for frequency sweeps by the spectrum analyzer.

#### OPT.76

Output impedance: 50 Ω

Output frequency range: 100 kHz to 3 GHz

#### OPT.77

Output impedance: 50 Ω

Output frequency range: 100 kHz to 6 GHz

### Functions for evaluating frequency characteristics

The normalize function enables direct measurement of cable loss and filter characteristics. The frequency offset function of the tracking generator enables measurement of frequency characteristics and conversion loss characteristics of mixers and other frequency conversion devices.

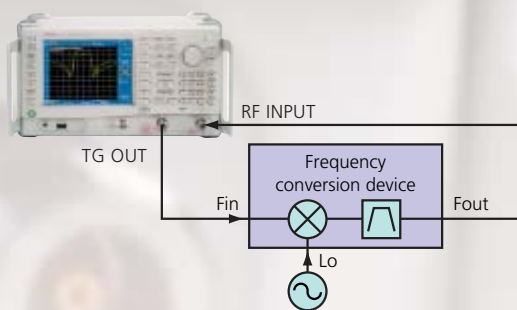

Measurement of mixer frequency conversion loss characteristics

### Function for return loss measurement

The SWR bridge can be used to measure reflection characteristics of an antenna or filter. It can determine the return loss and evaluate the VSWR.

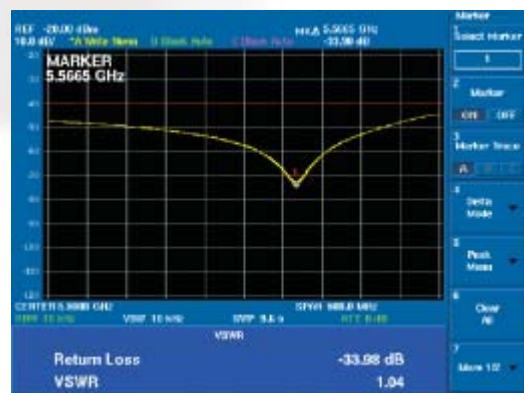
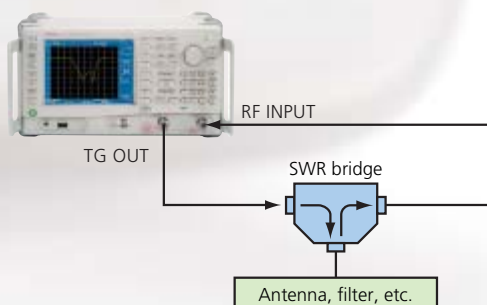

Filter return loss measurement

## Specifications

### Frequency

Frequency range	9 kHz to 8 GHz
RF input 1:	9 kHz to 3.1 GHz (band 0)
Frequency band:	3.0 GHz to 8.0 GHz (band 1)
Preamp:	10 MHz to 8 GHz
RF input 2:	10 MHz to 31.8 GHz (U3771)
	10 MHz to 43 GHz (U3772)
Frequency band:	10 MHz to 3.1 GHz (band 0, N=1)
	3.0 to 8.0 GHz (band 1, N=1)
	7.8 to 14.573 GHz (band 2, N=2)
	14.4288 to 28.0 GHz (band 3, N=4)
	27.8 to 31.8 GHz (band 4, N=6, U3771)
	27.8 to 43.0 GHz (band 4, N=6, U3772)

Frequency reading accuracy:	$\pm$ (marker read value x frequency reference accuracy + span x span accuracy + residual FM)
-----------------------------	---

Frequency reference stability	
Aging rate:	$\pm 2 \times 10^{-6}$ /year
Temperature stability:	$\pm 2.5 \times 10^{-6}$ (0 to 50°C)

Frequency counter:	Resolution bandwidth $\leq 100$ kHz, span $\leq 100$ MHz, signal level: S/N > 50 dB
Resolution:	1 Hz to 1 kHz
Accuracy:	$\pm$ (counter read value x frequency reference accuracy + residual FM + 1 LSB)

Frequency stability	
Residual FM (zero/span):	< 60 Hz x Np-p/100 ms (internal frequency reference)

Frequency span	
Range:	5 kHz to Full, zero span 1 kHz to Full, zero span (with the OPT.70 installed)
Accuracy:	< $\pm 1\%$

Spectrum purity:	(-85 + 20 LogN) dBc/Hz, offset 10 kHz, span < 200 kHz
------------------	---

Resolution bandwidth	
Range:	100 Hz to 3 MHz (1 to 3 steps) 30 Hz to 3 MHz (with OPT.70/71 installed)
Accuracy:	< $\pm 12\%$

Video bandwidth range:	10 Hz to 3 MHz (1 to 3 steps)
------------------------	-------------------------------

### Sweep

Sweep time	
Setting range:	20 ms to 1000 s (spectrum mode) 50 $\mu$ s to 1000 s (zero span)
Accuracy:	< $\pm 2\%$ (zero span)
Sweep mode:	Continuous, single, gated
Trigger function	
Trigger source:	Free run, video, external, IF

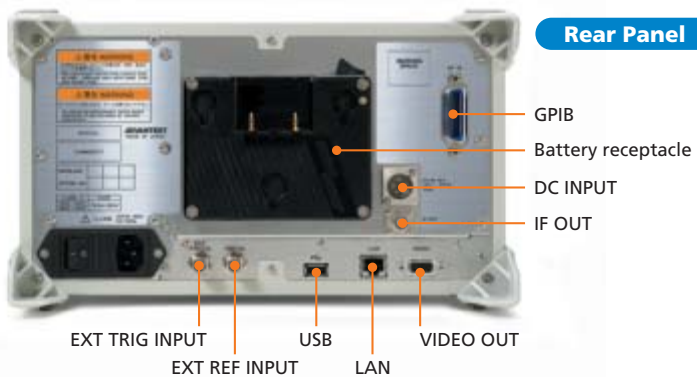
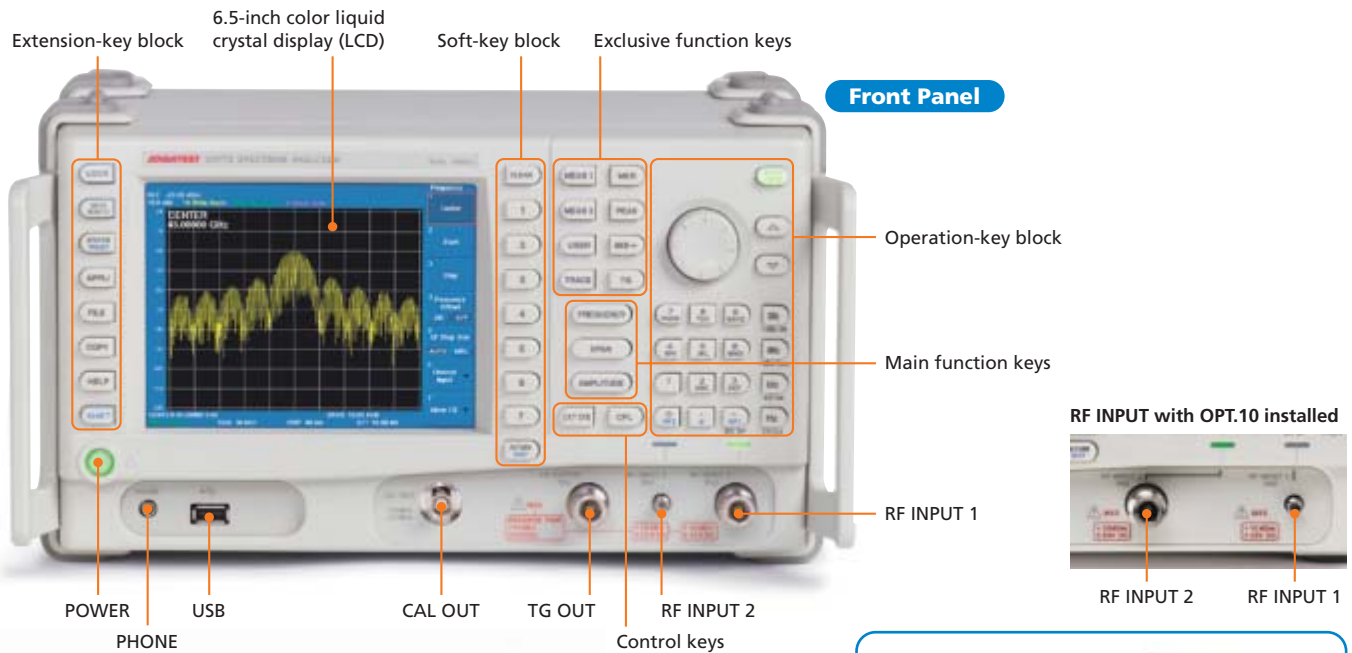

## Amplitude range

Measurement range:	
RF input 1:	Displayed average noise level to +30 dBm
RF input 2:	Displayed average noise level to +10 dBm
Maximum safe input level:	Attenuator $\geq$ 10 dB
RF input 1:	$\pm 15$ VDC max.
Preamp off:	+30 dBm (Attenuator $\geq$ 10 dB)
Preamp on:	+13 dBm (Attenuator 0 dB)
RF input 2:	+10 dBm (Attenuator 0 dB), $\pm 25$ VDC max.
Input attenuator range:	
RF input 1:	0 to 50 dB (10 dB steps)
RF input 2:	0 to 30 dB (10 dB steps)
Display range:	100/50/20/10/5 dB, linear
Scale unit:	dBm, dBmV, dB $\mu$ V, dB $\mu$ Vemf, dBpW, W, V
Reference level setting range:	
RF input 1:	-140 to +40 dBm
RF input 2:	-140 to +20 dBm
Detection mode:	Normal, Positive peak, Negative peak, Sample, RMS, and Average

## Amplitude accuracy

Calibration signal	
Frequency:	20 MHz
Level:	-20 dBm
Accuracy:	$\pm 0.3$ dB
Scale fidelity	
Log:	$\pm 0.5$ dB/10 dB $\pm 0.5$ dB/80 dB $\pm 0.2$ dB/1 dB
Level measurement accuracy:	After automatic calibration, image suppression off, Preamp off, at temperature 20 to 30°C, input attenuator 10 dB, reference level 0 dBm, input signal level -10 to -50 dBm
RF input 1	
Band 0:	$\pm 0.8$ dB (frequency: 10 MHz to 3.1 GHz)
Band 1:	$\pm 1$ dB (frequency: 3.1 to 8 GHz) $\pm 1.5$ dB (frequency: 9 kHz to 10 MHz)
RF input 2	
Band 0:	$\pm 0.8$ dB (frequency: 10 MHz to 3.1 GHz)
Band 1:	$\pm 1$ dB (frequency: 3.1 to 8 GHz)
Band 2:	$\pm 3.0$ dB (frequency: 7.8 to 14.573 GHz)
Band 3:	$\pm 3.5$ dB (frequency: 14.4288 to 28.0 GHz)
Band 4:	$\pm 4.5$ dB (frequency: 27.8 to 31.8 GHz, U3771) $\pm 4.5$ dB (frequency: 27.8 to 43 GHz, U3772)

## Dynamic range

Displayed average noise level:	Frequency >10 MHz, reference level $\leq -45$ dBm, at resolution bandwidth 100 Hz
RF input 1	
Band 0, Preamp off:	-123 dBm + 2f (GHz) dB
Band 1, Preamp off:	-122 dBm + 1.2f (GHz) dB
Band 0, Preamp on:	-138 dBm + 3f (GHz) dB
Band 1, Preamp on:	-139 dBm + 1.4f (GHz) dB
RF input 2	
Band 0:	-121 dBm + 2f (GHz) dB
Band 1:	-120 dBm + 1.5f (GHz) dB
Band 2:	-111 dBm (typical: -118 dBm)
Band 3:	-109 dBm (typical: -117 dBm)
Band 4:	-105 dBm (typical: -112 dBm)
1 dB gain compression:	Frequency: >10 MHz
Preamp off:	$> -8$ dBm
Preamp on:	$> -25$ dBm

Second harmonic distortion:	Preamp off $\leq -70$ dBc
RF input 1:	(mixer input level: -40 dBm; frequency: >200 MHz) $\leq -75$ dBc (typical)
RF input 2:	(mixer input level: -30 dBm; frequency: >300 MHz) $\leq -40$ dBc (mixer input level: -30 dBm) (U3771: 300 MHz to 31.8 GHz) (U3772: 300 MHz to 40 GHz)
Third order intermodulation distortion:	-50 dBc (frequency >10 MHz, Preamp off, mixer input level -20 dBm, 2-signal separation 1 MHz)
Image/Multiple/Out-of-band response	$\leq -60$ dBc (mixer input level -30 dBm, image suppression on, span <5 GHz)
Residual response:	-80 dBm (frequency >10 MHz, Preamp off)

## Inputs/outputs

RF input	
RF input 1	
Connector:	N type female
Impedance:	50 $\Omega$ (nominal)
VSWR:	Input attenuator $\geq$ 10 dB $< 1.7 : 1$ (10 MHz $\leq$ Frequency $\leq$ 3.0 GHz, Band 0) $< 2.0 : 1$ (Frequency > 3.0 GHz, Band 1)
RF input 2	
Connector:	K type female
Impedance:	50 $\Omega$ (nominal)
VSWR:	Input attenuator $\geq$ 10 dB 1.7 : 1 (typical, Band 0) 2.0 : 1 (typical, Band 1, Band 2, Band 3) 2.5 : 1 (typical, Band 4)
Calibration signal output	
Connector:	BNC female
Impedance:	50 $\Omega$ (nominal)
Frequency:	20 MHz
Level:	-20 dBm
Frequency reference input	
Connector:	BNC female
Impedance:	50 $\Omega$ (nominal)
Frequency (MHz):	1, 1.544, 2.048, 5, 10, 12.8, 13, 13.824, 14.4, 15.36, 15.4, 16.8, 19.2, 19.44, 19.6608, 19.68, 19.8, 20, 26
Level:	0 to +16 dBm
External trigger input	
Connector:	BNC female
Impedance:	10 k $\Omega$ (nominal), DC coupling
Level:	0 to +5 V
21.4-MHz IF output	
Connector:	BNC female
Impedance:	50 $\Omega$ (nominal)
Level:	Approx. mixer input level + 10 dB (at a frequency of 20 MHz)
Battery mount	
Connector:	AntonBauer QR mount
External DC power input	
Connector:	XLR-4
Voltage range:	+11 to +17 V
GPIB:	IEEE-488 bus connector
USB:	USB 1.1
Video output:	VGA (D-sub15 pin female)
LAN:	RJ45 type, 10/100 base-T
Audio output:	Small monophonic jack

## General specifications

Operating environment range:	Ambient temperature: 0 to + 50°C Humidity: RH 85% or less (no condensation)
Storage environment range:	-20 to +60°C, RH 85% or less
AC power input:	Automatic switching to 100 VAC or 200 VAC 100 V: 100 to 120 V, 50/60 Hz 200 V: 220 to 240 V, 50/60 Hz
DC power input:	DC + 11 V to +17 V
Power consumption:	100 VA or less (AC operation) 70 W or less (DC operation)
Mass:	6 kg or less (excluding options)
External dimensions (W x H x D):	Approx. 308 x 175 x 209 mm (not including protruding parts) Approx. 337 x 190 x 307 mm (including the handle and feet)

## OPT.10 2 Channel input (50 Ω, 3 GHz)

Cross talk between input channels (between RF input 1 and RF input 2):	<-90 dBc (Input level -10 dBm, Input attenuator 0 dB, Preamplifier off)
RF input 2 Connector:	N type female
Impedance:	50 Ω (nominal)
VSWR:	<1.5 : 1 (Input attenuator > 10 dB)
External trigger input:	An external trigger input can be selected as a trigger input of RF input 2 when installing the OPT.10. The input connector is only 1 system.
21.4 MHz IF output:	Only IF output which supports RF input 1, when installing the OPT.10.

Except for all items mentioned above, the frequency, sweep, amplitude range, amplitude accuracy, dynamic range, input/output, and performance of specifications follow the standard specifications of the RF input 1 option of the U3741 3 GHz spectrum analyzer.

## OPT.20 High-stability frequency reference source

Frequency reference stability	
Aging rate:	±2 x 10 <sup>-9</sup> /day ±1 x 10 <sup>-7</sup> /year
Warm-up drift:	±5 x 10 <sup>-8</sup> (+25°C, 10 minutes after power-on)
Temperature stability:	±5 x 10 <sup>-8</sup> (0 to +40°C, with reference to 25°C)

## OPT.28 EMC filter

6 dB bandwidth:	200 Hz, 9 kHz, 120 kHz, 1 MHz
Bandwidth accuracy:	< ±10%

## OPT.53/54 Time-domain analysis (1 ch/2 ch)

RF range:	Follows the U3771/3772.
RF amplitude range:	Noise level to +30 dBm <sup>*1)</sup>
Wave recording method:	I/Q vector time waveform
Measuring bandwidth (CBW):	100 Hz to 3 MHz (1 to 3 steps)
IQ sampling rate:	713 Hz (BW 100 Hz) to 21.4 MHz (BW 3 MHz)
IQ waveform recording time:	49 msec (BW 3 MHz) to 1000 sec (BW 100 Hz)
Number of IQ waveform recording samples:	1 M samples (I/Q)

\*1) The noise level follows the dynamic range of the U3771/3772.

## OPT.55/56 Wide-band time-domain analysis (1 ch/2 ch)

RF range:	Follows the U3771/3772.
RF amplitude range:	Noise level to +30 dBm <sup>*1)</sup>
Wave recording method:	I/Q vector time waveform
Measuring bandwidth (CBW):	100 Hz to 30 MHz (1 to 3 steps), 40 MHz
IQ sampling rate:	500 Hz (BW 100 Hz) to 65 MHz (BW 40 MHz)
IQ waveform recording time:	120 msec (BW 40 MHz) to 1000 sec (BW 100 Hz)
Number of IQ waveform recording samples:	8 M samples (I/Q)

\*1) The noise level follows the dynamic range of the U3771/3772.

## OPT.70/71 High-purity spectrum analysis (1ch/2 ch)

Frequency span	
Range:	1 kHz to Full, zero span
Accuracy:	< ±1%
Resolution bandwidth	
Range:	30 Hz to 3 MHz (1 to 3 steps)
Accuracy:	< ±12%
Spectrum purity:	≤ (-98 + 20 LogN) dBc/Hz (offset 10 kHz, span ≤ 1 MHz) (-102 + 20 LogN) dBc/Hz (typical)
Displayed average noise level:	Frequency >10MHz, Reference level <-45dBm, Resolution bandwidth 30 Hz
RF input 1	
Preamp OFF:	-126 dBm + 2f (GHz) dB (band 0) -125 dBm + 1.2f (GHz) dB (band1)
Preamp ON:	-141 dBm + 3f (GHz) dB (band 0) -142 dBm + 1.4f (GHz) dB (band 1)
RF input 2:	-124 dBm + 2f (GHz) dB (band 0) -123 dBm + 1.5f (GHz) dB (band 1) -114 dBm (band 2) -112 dBm (band 3) -108 dBm (band 4)

## OPT.76 Tracking generator (50 Ω, 3 GHz)

Frequency range:	100 kHz to 3 GHz
Frequency offset	
Range:	0 Hz to 1 GHz
Accuracy:	±300 Hz
Resolution:	1 kHz
Output level range:	0 to -60 dBm (0.5 dB steps)
Output level accuracy:	±0.5 dB (20 MHz, -10 dBm, +20 to +30°C)
Output level flatness:	Using 20 MHz and -10 dBm as a reference ±1.0 dB (1 MHz to 1 GHz) ±1.5 dB (100 kHz to 3 GHz)
Output level switch error:	Using -10 dBm as a reference ±1.0 dB (1 MHz to 1 GHz, 0 to -60 dBm) ±2.0 dB (1 MHz to 2.6 GHz, 0 to -60 dBm) ±3.0 dB (100 kHz to 3 GHz, 0 to -30 dBm) ±4.0 dB (100 kHz to 3 GHz, -30.5 to -60 dBm) ±5.0 dB (100 kHz to 3 GHz, 0 to -60 dBm)
Frequency offset ON:	
Output spurious:	Output level -10 dBm
Harmonic:	≤ -15 dBc (100 kHz to 1 MHz) ≤ -20 dBc (1 MHz to 3 GHz)
Non-harmonic:	≤ -20 dBc (Frequency offset OFF)
TG leakage:	≤ -80 dBm (Input attenuator 0 dB)
Output impedance:	50 Ω (nominal)
VSWR:	≤2.0 : 1 (Output level ≤ -10 dBm)
Maximum allowable level:	+10 dBm, ±10 VDC

## OPT.77 Tracking generator (50 Ω, 6 GHz)

Frequency range:	100 kHz to 6 GHz
Output level range:	0 to -30 dBm (0.5 dB step)
Output level accuracy:	≤ ±0.5 dB (20 MHz, -10 dBm, +20 to +30°C) 20 MHz on -10 dBm criterion, at +20 to +30°C
Output level flatness:	≤ ±1 dB (1 MHz to 1 GHz) ≤ ±1.5 dB (100 kHz to 3.1 GHz) ≤ ±2.0 dB (100 kHz to 6 GHz)
TG leakage:	≤ -80 dBm (input attenuator: 0 dB)
Output impedance:	50 Ω (nominal)
VSWR:	≤ 2.0 : 1 (Output level ≤ -10 dBm)
Maximum allowable level:	+10 dBm, ±10 VDC

## A199001 6 GHz VSWR bridge

Frequency range:	100 MHz to 6 GHz
Directivity:	≥34 dB (100 MHz to 1 GHz) ≥29 dB (1 to 3.8GHz) ≥25 dB (3.8 to 6GHz)
Maximum input power:	+15 dBm (Input Port)
DC voltage:	±30 VDC ( Test Port)
Connector:	SMA (female)
External dimensions (W x H x D):	Approx. 103 x 35 x 20 mm
Mass:	100 g or less

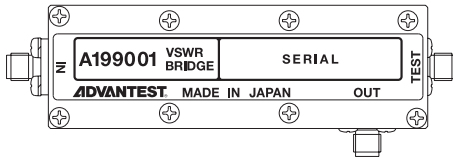

### Ordering information

<b>Main unit</b>	
Spectrum analyzer:	U3771 U3772

<b>Accessories</b>	
Operating manual (CD):	BU3700S
Power cable:	A01412
Input cable:	A01037-0300
N-BNC adapter:	JUG-201A/U
K-K adapter:	HE-A-PJ
BNC-SMA adapter:	HRM-517
Ferrite core:	ESD-SR-120
Ferrite core:	E04SR150718

<b>Options</b>	
2 Channel input (50 Ω)*:	OPT.10
High-stability frequency reference source:	OPT.20
EMC filter:	OPT.28
Time-domain analysis (1 ch):	OPT.53
Time-domain analysis (2 ch):	OPT.54
Wide-band time-domain analysis (1 ch):	OPT.55
Wide-band time-domain analysis (2 ch):	OPT.56
High-purity spectrum analysis (1 ch):	OPT.70
High-purity spectrum analysis (2 ch):	OPT.71
Tracking generator (3 GHz):	OPT.76
Tracking generator (6 GHz):	OPT.77

<b>Accessories</b>	
Filter for spurious measurement (2.8 to 18 GHz HPF):	A899001
Filter for spurious measurement (8 to 18 GHz HPF):	A899002
Filter for spurious measurement (11 to 26 GHz HPF):	A899003
Filter for spurious measurement (18 to 30 GHz HPF):	A899004
Japanese operating manual (printed manual):	JU3700S
English operating manual (printed manual):	EU3700S
Battery pack:	A870008
Charger:	A870009
75 Ω input impedance converter:	ZT-130NC
DC power cable:	A114020
Carrying bag:	A129001
Transit case:	A129002
Rack mount kit (JIS):	A122003
Rack mount kit (EIA):	A124004
6 GHz VSWR bridge:	A199001

Note on accessories:  
The operating manual on the CD is supplied as standard.  
The printed version of the operating manual is offered as an accessory.

\*: When OPT.10 is installed, the standard equipment, 9 kHz to 8 GHz, is deleted, RF1 is 10 MHz to 31.8 GHz (U3771)/10 MHz to 43 GHz (U3772), and RF2 is 9 kHz to 3 GHz.

Please refer to product manual for complete system specifications.  
Specifications may change without notification.

## Sample software

to be downloaded free from homepage

ADVANTEST provides various kinds of sample software shown below :

- Useful sample software for EMI measurement and Radio waves monitor, etc.
- Module software with source code to control a Spectrum analyzer for developers.

<http://www.advantest.co.jp/en-index.shtml>

PRODUCTS & SUPPORT

Electronic Measuring Instruments Products

U3771/U3772

Sample Software

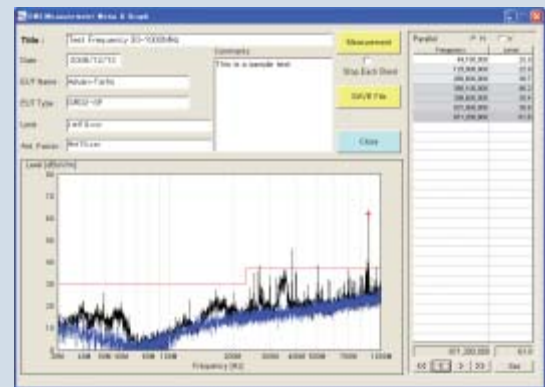

EMI measurement software (2 ch)



Radio waves monitor (1 ch/2ch)

**ADVANTEST**<sup>®</sup>

<http://www.advantest.co.jp>

---

ADVANTEST CORPORATION

Shin-Marunouchi Center Building, 1-6-2 Marunouchi, Chiyoda-ku, Tokyo 100-0005, Japan Phone: +81-3-3214-7500